

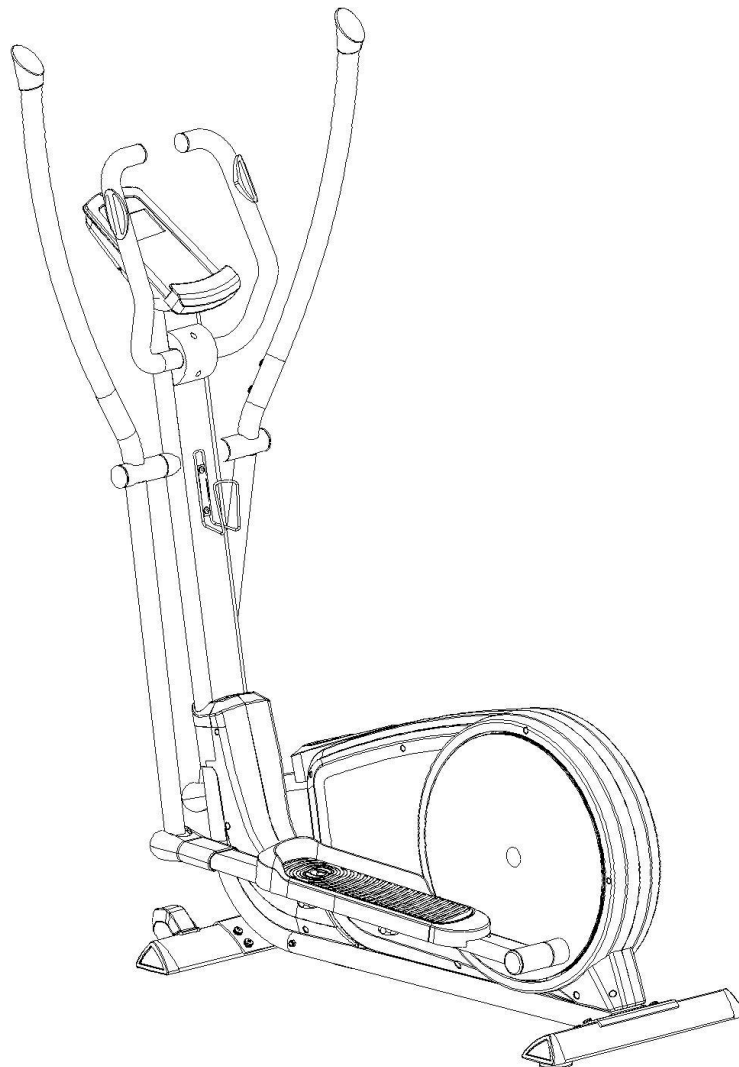

**MANUAL DE UTILIZARE**

**IN 8724 Bicicleta eliptica inSPORTline inCondi  
ET600i**



## CUPRINS

INSTRUCTIUNI DE SIGURANTA.....	3
VEDERE DE ANSAMBLU .....	4
LISTA COMPONENTE .....	5
CONTINUT COLET.....	9
INSTRUCTIUNI DE ASAMBLARE.....	10
SM2570 iConsole+ MANUAL DE INSTRUCTIUNI .....	16



## INSTRUCTIUNI DE SIGURANTA

- Verificati in mod regulat daca bicicleta prezinta semne de uzura sau componente defecte.
- Daca bicicleta este folosita de catre mai multi utilizatori, asigurati-va ca acestia sunt informati cu privire la instructiunile de siguranta.
- Este interzis ca mai multe persoane sa foloseasca bicicleta in acelasi timp.
- Inainte de prima utilizare, asigurati-va ca toate suruburile si piulitele sunt bine stranse.
- Inainte de a incepe antrenamentul, indepartati toate obiectele ascutite din preajma aparatului.
- Utilizati bicicleta doar daca functioneaza normal.
- Orice componenta defecta sau uzata trebuie inlocuita imediat.
- Daca permiteti copiilor sa foloseasca produsul, supravegheati-i in permanenta.
- Asigurati suficient spatiu in jurul aparatului atunci cand incepeti sa il asamblati.
- Antrenamentul incorect sau excesiv poate dauna sanatatii dvs.
- Plasati bicicleta pe o suprafata dreapta, solida.
- Purtati imbracaminte si incaltaminte sport atunci cand folositi bicicleta. Atentie! Hainele prea largi sau prea lungi se pot agata de aparat.
- Inainte de a incepe orice program de exercitii, consultati medicul.
- Asamblati bicicleta conform instructiunilor din manual. Verificati daca in cutie se afla toate componentele necesare.
- Asamblati aparatul pe o suprafata uscata si dreapta, intr-un loc ferit de umiditate. Asezati un covoras anti-alunecare sub bicicleta.
- Opriti antrenamentul imediat daca aveti urmatoarele simptome: ameteala, greata, dureri in piept sau orice alte simptome anormale.
- Copiii si persoanele cu dizabilitati pot folosi bicicleta doar sub supravegherea unui adult.
- La componentele ajustabile, nu depasiti marcajele de maxim si minim.
- Nu va antrenati imediat dupa ce ati mancat!

# VEDERE DE ANSAMBLU

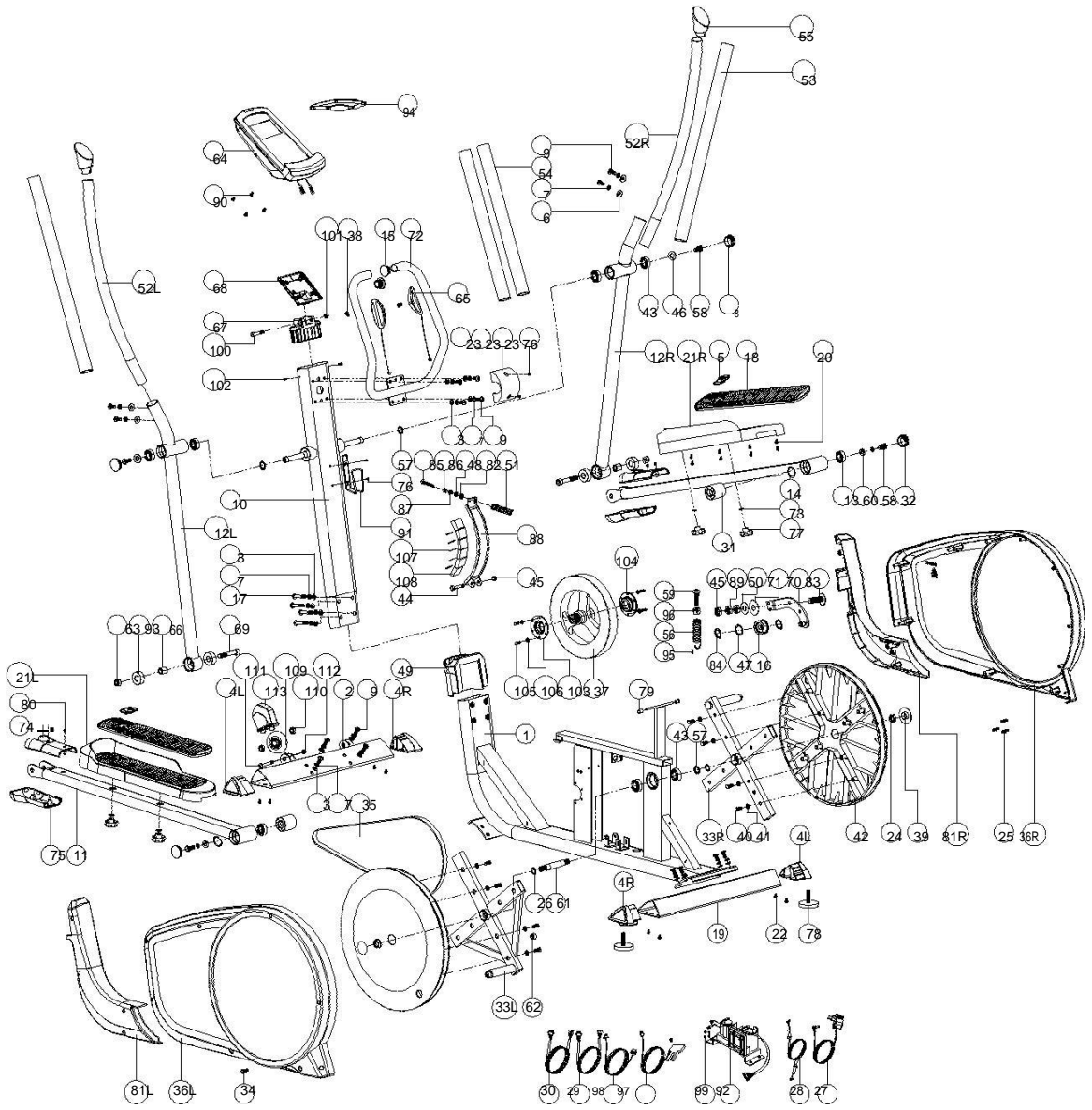

## LISTA COMPONENTE

NR.	Denumire	CANTITATE
1	Cadru principal	1
2	Stabilizator anterior	1
3	Saiba plata D16xD8.5x1.2T	16
4L	Capac- forma triunghi (stang)	2
4R	Capac-forma triunghi (drept)	2
5	Capac decorativ	2
6	Saiba curbata D22xD8.5x1.5T	4
7	Saiba grower D15.4xD8.2x2T	20
8	Capac	2
9	Surub imbus M8x1.25x20L	16
10	Suport ghidon	1
11	Suport pedale	2
12L	Tub inferior stang al manerului mobil	1
12R	Tub inferior drept al manerului mobil	1
13	Rulment #2203-2RS	2
14	Inel de siguranta S-40(1.80T)	2
15	Capac	2
16	Rotita	1
17	Surub imbus M8*50L	4
18	Pedale	2
19	Stabilizator posterior	1
20	Surub ST4*1.41*14L	16
21L	Pedala stanga	1
21R	Pedala dreapta	1
22	Surub ST4*1.41*12L	8
23	Capac de protectie	1
24	Piulita cu autoblocare M10*1.25*10T	2
25	Stift	3
26	Inel de siguranta D22.5*D18.5*1.2T	2
27	Adaptor	1
28	Cablu rezistenta	1
29	Cablu superior calculator	1
30	Cablu inferior calculator	1
31	Protectie ax	2
32	Capac rotund	2



33L	Brat pedalier stang	1
33R	Brat pedalier drept	1
34	Surub ST4.2x1.4x20L	16
35	Curea	1
36L	Carcasa stanga	1
36R	Carcasa dreapta	1
37	Volanta	1
38	Surub ST4.0x1.41x20L	2
39	Capac lateral	2
40	Surub M6*1.0*15L	16
41	Saiba plata D14*D6.5*0.8T	16
42	Disc	2
43	Rulment #6004-2RS(C0)	6
44	Surub M8*52L	1
45	Piulita plastic M8*1.25*8T	2
46	Saiba plata D25xD8.5x2.0T	2
47	Saiba ondulata D21xD16.2x0.3T	1
48	Saiba ondulata D13*D6.5*1.0T	1
49	Capac protectie superior	1
50	Saiba plastic D50*D10*1.0T	1
51	Arc D1.0*55L	1
52L	Maner mobil stang	1
52R	Maner mobil drept	1
53	Spuma	2
54	Spuma	2
55	Capac	2
56	Arc D3*D19*67L	1
57	Saiba ondulata D27*D20.3*0.5T	3
58	Surub M8x1.25x20	4
59	Surub imbus M8*1.25*50L	1
60	Saiba plata D21xD8.5x1.5T	2
61	Ax pedala	1
62	Magnet	1
63	Piulita plastic M12*1.75*12T	2
64	Calculator SM-2570-71	1
65	Senzor puls	2
	Cablu pentru senzor puls	2
66	Bucsa D19*26.4L	2

67	Suport calculator	1
68	Placuta de suport pentru calculator	1
69	Surub imbus M12*1.75*70L	2
70	Suport	1
71	Saiba plata D50*D10*3T	1
72	Ghidon fix	1
73	Saiba plata D14xD6.5x0.8T	4
74	Capac decorativ (superior)	2
75	Capac decorativ (inferior)	2
76	Surub M5x0.8x15L	4
77	Piulita	4
78	Rotita	2
79	Tampon	2
80	Surub ST3.5x1.27x15L	4
81L	Capac decorativ anterior (stang)	1
81R	Capac decorativ anterior (drept)	1
82	Piulita plastic M6*1*6T	1
83	Surub imbus M8x1.25x30L	1
84	Inel siguranta S-16(1T)	2
85	Surub M6*65L	1
86	Piulita M6*1*6T	1
87	Saiba plastic D6*D19*1.5T	1
88	Suport pentru magneti	1
89	Piulita M8*1.25*6T	2
90	Surub M5x0.8x10L	4
91	Suport sticla	1
92	Sursa de alimentare	1
93	Rulment	4
94	Centura piept	1
95	Capac plastic	1
96	Piulita D15*13L	1
97	Senzor	1
98	Cablu electric	1
99	Surub ST4.2x1.4x15L	4
100	Surub imbus M8*1.25*45L	1
101	Piulita plastic M8*1.25*8T	1
102	Surub ST4.2x1.4x15L	2
103	Disc fixare (1)	1

104	Disc fixare (2)	1
105	Surub M5*0.8*15L	4
106	Saiba plata D12*D5.2*0.8T	4
107	Componente magnet	5
108	Magnet	6
109	Roti de transport	2
110	Bucsa D22.2*D8.2*7T	4
111	Surub imbus M8*1.25*40L	2
112	Piulita plastic M8*1.25*8T	2
113	Capace roti de transport	2

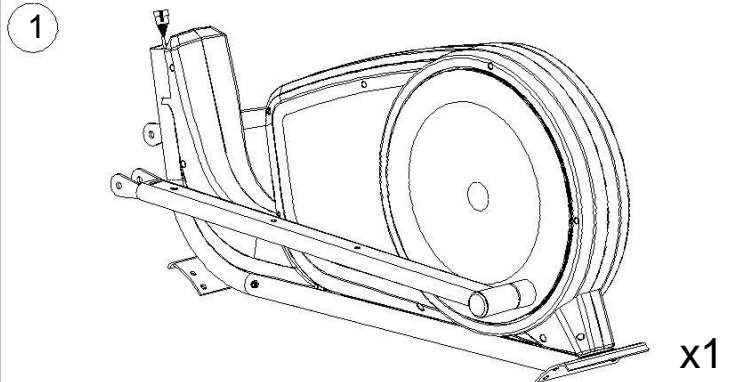
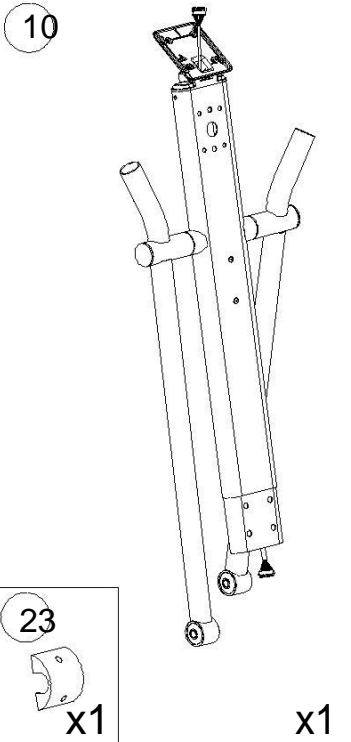
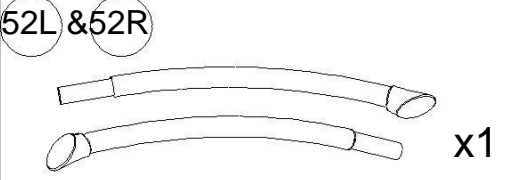
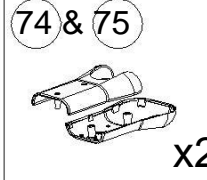
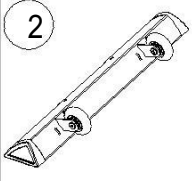
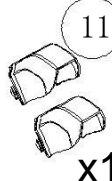
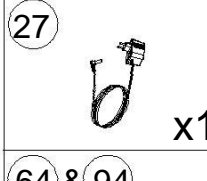
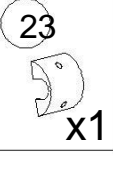
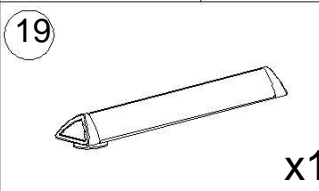
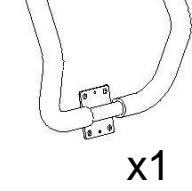
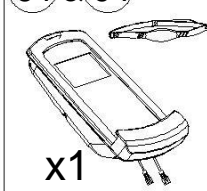
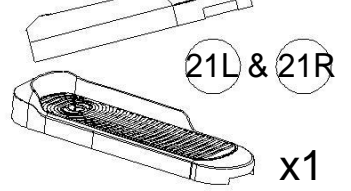

# LISTA VERIFICARE (CONTINUT COLET)

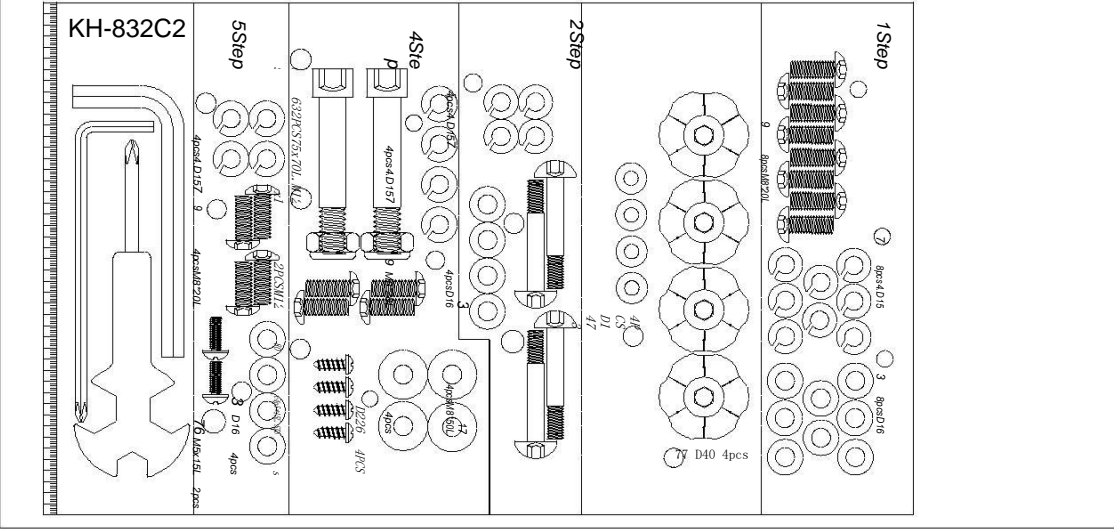
 <p>1 x1</p>		 <p>10 x1</p>	
 <p>52L &amp; 52R x1</p>		 <p>74 &amp; 75 x2</p>	
 <p>2 x1</p>	 <p>113 &amp; 72 x1</p>	 <p>27 x1</p>	 <p>23 x1</p>
 <p>19 x1</p>	 <p>72 x1</p>	 <p>64 &amp; 94 x1</p>	 <p>21L &amp; 21R x1</p>
 <p>49 x1</p>	 <p>91 x1</p>		
 <p><b>KH-832C2</b></p> <p><b>1Step</b></p> <ul style="list-style-type: none"> <li>7 8x6x15 3</li> <li>8 8x6x16 3</li> <li>9 8x6x20 1</li> <li>10 D40 4pcs</li> </ul> <p><b>2Step</b></p> <ul style="list-style-type: none"> <li>1 4x6x16</li> <li>2 4x6x16</li> <li>3 4x6x16</li> <li>4 4x6x16</li> <li>5 4x6x16</li> <li>6 4x6x16</li> <li>7 4x6x16</li> <li>8 4x6x16</li> <li>9 4x6x16</li> <li>10 4x6x16</li> <li>11 4x6x16</li> <li>12 4x6x16</li> <li>13 4x6x16</li> <li>14 4x6x16</li> <li>15 4x6x16</li> <li>16 4x6x16</li> <li>17 4x6x16</li> <li>18 4x6x16</li> <li>19 4x6x16</li> <li>20 4x6x16</li> <li>21 4x6x16</li> <li>22 4x6x16</li> <li>23 4x6x16</li> <li>24 4x6x16</li> <li>25 4x6x16</li> <li>26 4x6x16</li> <li>27 4x6x16</li> <li>28 4x6x16</li> <li>29 4x6x16</li> <li>30 4x6x16</li> <li>31 4x6x16</li> <li>32 4x6x16</li> <li>33 4x6x16</li> <li>34 4x6x16</li> <li>35 4x6x16</li> <li>36 4x6x16</li> <li>37 4x6x16</li> <li>38 4x6x16</li> <li>39 4x6x16</li> <li>40 4x6x16</li> <li>41 4x6x16</li> <li>42 4x6x16</li> <li>43 4x6x16</li> <li>44 4x6x16</li> <li>45 4x6x16</li> <li>46 4x6x16</li> <li>47 4x6x16</li> <li>48 4x6x16</li> <li>49 4x6x16</li> <li>50 4x6x16</li> <li>51 4x6x16</li> <li>52 4x6x16</li> <li>53 4x6x16</li> <li>54 4x6x16</li> <li>55 4x6x16</li> <li>56 4x6x16</li> <li>57 4x6x16</li> <li>58 4x6x16</li> <li>59 4x6x16</li> <li>60 4x6x16</li> <li>61 4x6x16</li> <li>62 4x6x16</li> <li>63 4x6x16</li> <li>64 4x6x16</li> <li>65 4x6x16</li> <li>66 4x6x16</li> <li>67 4x6x16</li> <li>68 4x6x16</li> <li>69 4x6x16</li> <li>70 4x6x16</li> <li>71 4x6x16</li> <li>72 4x6x16</li> <li>73 4x6x16</li> <li>74 4x6x16</li> <li>75 4x6x16</li> <li>76 4x6x16</li> <li>77 4x6x16</li> <li>78 4x6x16</li> <li>79 4x6x16</li> <li>80 4x6x16</li> <li>81 4x6x16</li> <li>82 4x6x16</li> <li>83 4x6x16</li> <li>84 4x6x16</li> <li>85 4x6x16</li> <li>86 4x6x16</li> <li>87 4x6x16</li> <li>88 4x6x16</li> <li>89 4x6x16</li> <li>90 4x6x16</li> <li>91 4x6x16</li> <li>92 4x6x16</li> <li>93 4x6x16</li> <li>94 4x6x16</li> <li>95 4x6x16</li> <li>96 4x6x16</li> <li>97 4x6x16</li> <li>98 4x6x16</li> <li>99 4x6x16</li> <li>100 4x6x16</li> </ul> <p><b>4Step</b></p> <ul style="list-style-type: none"> <li>1 4x6x157</li> <li>2 4x6x157</li> <li>3 4x6x157</li> <li>4 4x6x157</li> <li>5 4x6x157</li> <li>6 4x6x157</li> <li>7 4x6x157</li> <li>8 4x6x157</li> <li>9 4x6x157</li> <li>10 4x6x157</li> <li>11 4x6x157</li> <li>12 4x6x157</li> <li>13 4x6x157</li> <li>14 4x6x157</li> <li>15 4x6x157</li> <li>16 4x6x157</li> <li>17 4x6x157</li> <li>18 4x6x157</li> <li>19 4x6x157</li> <li>20 4x6x157</li> <li>21 4x6x157</li> <li>22 4x6x157</li> <li>23 4x6x157</li> <li>24 4x6x157</li> <li>25 4x6x157</li> <li>26 4x6x157</li> <li>27 4x6x157</li> <li>28 4x6x157</li> <li>29 4x6x157</li> <li>30 4x6x157</li> <li>31 4x6x157</li> <li>32 4x6x157</li> <li>33 4x6x157</li> <li>34 4x6x157</li> <li>35 4x6x157</li> <li>36 4x6x157</li> <li>37 4x6x157</li> <li>38 4x6x157</li> <li>39 4x6x157</li> <li>40 4x6x157</li> <li>41 4x6x157</li> <li>42 4x6x157</li> <li>43 4x6x157</li> <li>44 4x6x157</li> <li>45 4x6x157</li> <li>46 4x6x157</li> <li>47 4x6x157</li> <li>48 4x6x157</li> <li>49 4x6x157</li> <li>50 4x6x157</li> <li>51 4x6x157</li> <li>52 4x6x157</li> <li>53 4x6x157</li> <li>54 4x6x157</li> <li>55 4x6x157</li> <li>56 4x6x157</li> <li>57 4x6x157</li> <li>58 4x6x157</li> <li>59 4x6x157</li> <li>60 4x6x157</li> <li>61 4x6x157</li> <li>62 4x6x157</li> <li>63 4x6x157</li> <li>64 4x6x157</li> <li>65 4x6x157</li> <li>66 4x6x157</li> <li>67 4x6x157</li> <li>68 4x6x157</li> <li>69 4x6x157</li> <li>70 4x6x157</li> <li>71 4x6x157</li> <li>72 4x6x157</li> <li>73 4x6x157</li> <li>74 4x6x157</li> <li>75 4x6x157</li> <li>76 4x6x157</li> <li>77 4x6x157</li> <li>78 4x6x157</li> <li>79 4x6x157</li> <li>80 4x6x157</li> <li>81 4x6x157</li> <li>82 4x6x157</li> <li>83 4x6x157</li> <li>84 4x6x157</li> <li>85 4x6x157</li> <li>86 4x6x157</li> <li>87 4x6x157</li> <li>88 4x6x157</li> <li>89 4x6x157</li> <li>90 4x6x157</li> <li>91 4x6x157</li> <li>92 4x6x157</li> <li>93 4x6x157</li> <li>94 4x6x157</li> <li>95 4x6x157</li> <li>96 4x6x157</li> <li>97 4x6x157</li> <li>98 4x6x157</li> <li>99 4x6x157</li> <li>100 4x6x157</li> </ul> <p><b>5Step</b></p> <ul style="list-style-type: none"> <li>1 4x6x157 9</li> <li>2 4x6x157 9</li> <li>3 D16 4pcs</li> <li>4 4x6x157 2pcs</li> <li>5 4x6x157 2pcs</li> <li>6 4x6x157 2pcs</li> <li>7 4x6x157 2pcs</li> <li>8 4x6x157 2pcs</li> <li>9 4x6x157 2pcs</li> <li>10 4x6x157 2pcs</li> <li>11 4x6x157 2pcs</li> <li>12 4x6x157 2pcs</li> <li>13 4x6x157 2pcs</li> <li>14 4x6x157 2pcs</li> <li>15 4x6x157 2pcs</li> <li>16 4x6x157 2pcs</li> <li>17 4x6x157 2pcs</li> <li>18 4x6x157 2pcs</li> <li>19 4x6x157 2pcs</li> <li>20 4x6x157 2pcs</li> <li>21 4x6x157 2pcs</li> <li>22 4x6x157 2pcs</li> <li>23 4x6x157 2pcs</li> <li>24 4x6x157 2pcs</li> <li>25 4x6x157 2pcs</li> <li>26 4x6x157 2pcs</li> <li>27 4x6x157 2pcs</li> <li>28 4x6x157 2pcs</li> <li>29 4x6x157 2pcs</li> <li>30 4x6x157 2pcs</li> <li>31 4x6x157 2pcs</li> <li>32 4x6x157 2pcs</li> <li>33 4x6x157 2pcs</li> <li>34 4x6x157 2pcs</li> <li>35 4x6x157 2pcs</li> <li>36 4x6x157 2pcs</li> <li>37 4x6x157 2pcs</li> <li>38 4x6x157 2pcs</li> <li>39 4x6x157 2pcs</li> <li>40 4x6x157 2pcs</li> <li>41 4x6x157 2pcs</li> <li>42 4x6x157 2pcs</li> <li>43 4x6x157 2pcs</li> <li>44 4x6x157 2pcs</li> <li>45 4x6x157 2pcs</li> <li>46 4x6x157 2pcs</li> <li>47 4x6x157 2pcs</li> <li>48 4x6x157 2pcs</li> <li>49 4x6x157 2pcs</li> <li>50 4x6x157 2pcs</li> <li>51 4x6x157 2pcs</li> <li>52 4x6x157 2pcs</li> <li>53 4x6x157 2pcs</li> <li>54 4x6x157 2pcs</li> <li>55 4x6x157 2pcs</li> <li>56 4x6x157 2pcs</li> <li>57 4x6x157 2pcs</li> <li>58 4x6x157 2pcs</li> <li>59 4x6x157 2pcs</li> <li>60 4x6x157 2pcs</li> <li>61 4x6x157 2pcs</li> <li>62 4x6x157 2pcs</li> <li>63 4x6x157 2pcs</li> <li>64 4x6x157 2pcs</li> <li>65 4x6x157 2pcs</li> <li>66 4x6x157 2pcs</li> <li>67 4x6x157 2pcs</li> <li>68 4x6x157 2pcs</li> <li>69 4x6x157 2pcs</li> <li>70 4x6x157 2pcs</li> <li>71 4x6x157 2pcs</li> <li>72 4x6x157 2pcs</li> <li>73 4x6x157 2pcs</li> <li>74 4x6x157 2pcs</li> <li>75 4x6x157 2pcs</li> <li>76 4x6x157 2pcs</li> <li>77 4x6x157 2pcs</li> <li>78 4x6x157 2pcs</li> <li>79 4x6x157 2pcs</li> <li>80 4x6x157 2pcs</li> <li>81 4x6x157 2pcs</li> <li>82 4x6x157 2pcs</li> <li>83 4x6x157 2pcs</li> <li>84 4x6x157 2pcs</li> <li>85 4x6x157 2pcs</li> <li>86 4x6x157 2pcs</li> <li>87 4x6x157 2pcs</li> <li>88 4x6x157 2pcs</li> <li>89 4x6x157 2pcs</li> <li>90 4x6x157 2pcs</li> <li>91 4x6x157 2pcs</li> <li>92 4x6x157 2pcs</li> <li>93 4x6x157 2pcs</li> <li>94 4x6x157 2pcs</li> <li>95 4x6x157 2pcs</li> <li>96 4x6x157 2pcs</li> <li>97 4x6x157 2pcs</li> <li>98 4x6x157 2pcs</li> <li>99 4x6x157 2pcs</li> <li>100 4x6x157 2pcs</li> </ul>			

# INSTRUCTIUNI DE ASAMBLARE

## PASUL 1

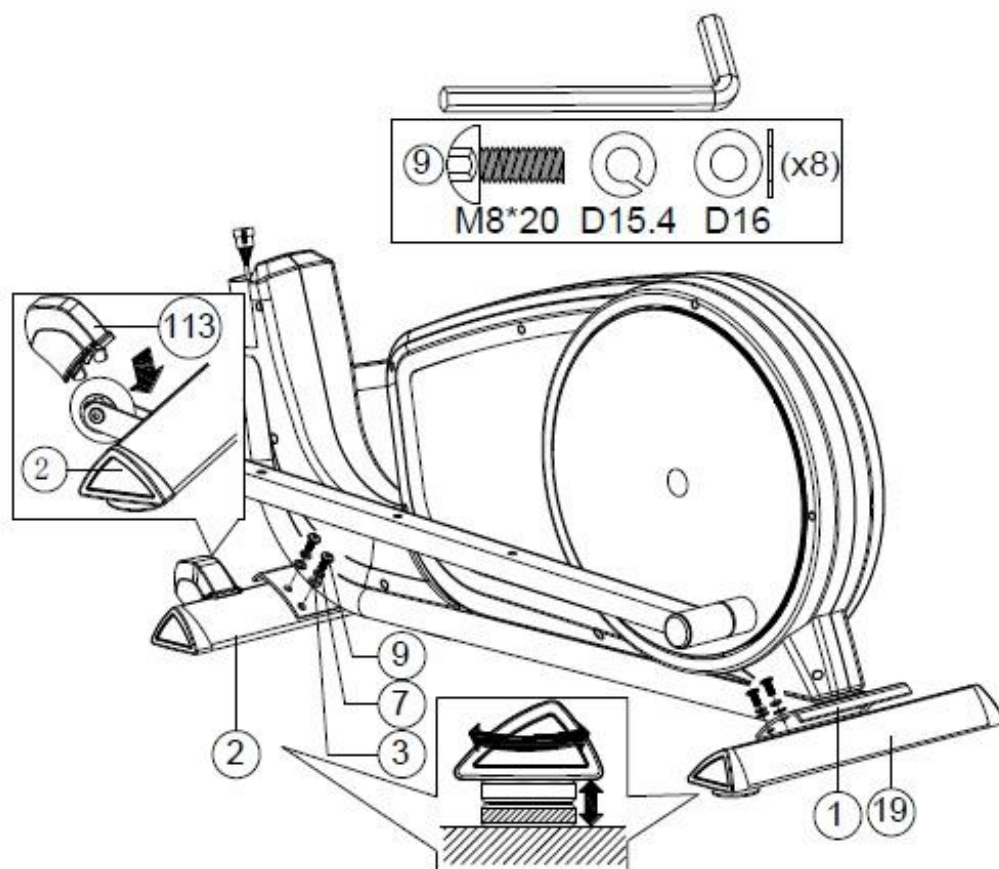

- 1) Atasati stabilizatorul anterior (2) si stabilizatorul posterior (19) la cadrul principal (1) folosind saiba plata (3), saiba grower (7), surubul imbus (9).
- 2) Reglati inaltimea dorita cu ajutorul rotitelor (78).
- 3) Atasati capacele rotilor de transport (113) la stabilizatorul anterior (2).

## PASUL 2

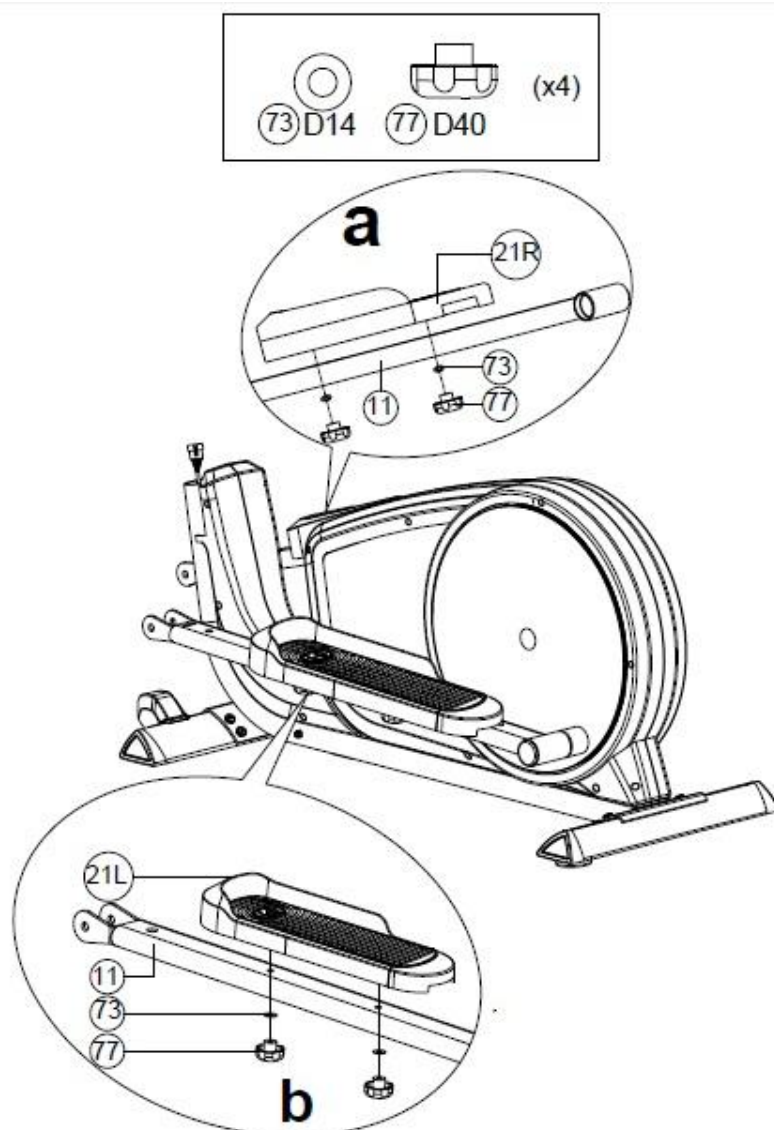

- 1) Atasati pedala dreapta si stanga (21L&21R) la suportul pentru pedale (11) folosind saiba plata (73) si piulita (77).
- 2) Exista 3 pozitii diferite de montare a pedalelor.

### PASUL 3

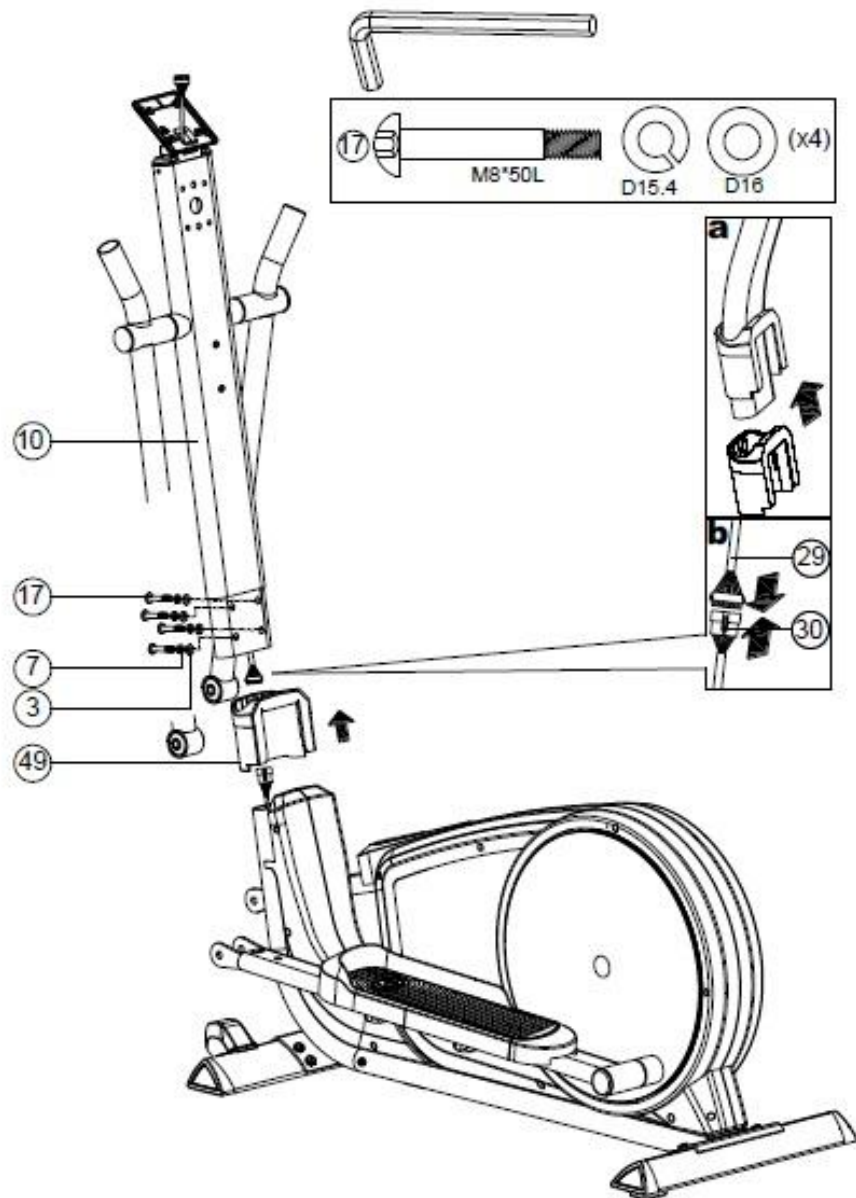

- 1) Acest pas necesita 2 persoane.
- 2) Intai ridicati capacul de protectie superior (49) conform figurii (a), apoi conectati cablurile calculatorului (29 si 30) conform figurii (b)
- 3) Inserati suportul ghidonului (10) in cadrul principal si fixati cu ajutorul saibei (3), saibei grower (7) si a surubului imbus (17). Fixati capacul de protectie superior (49) pe cadrul principal.

## PASUL 4

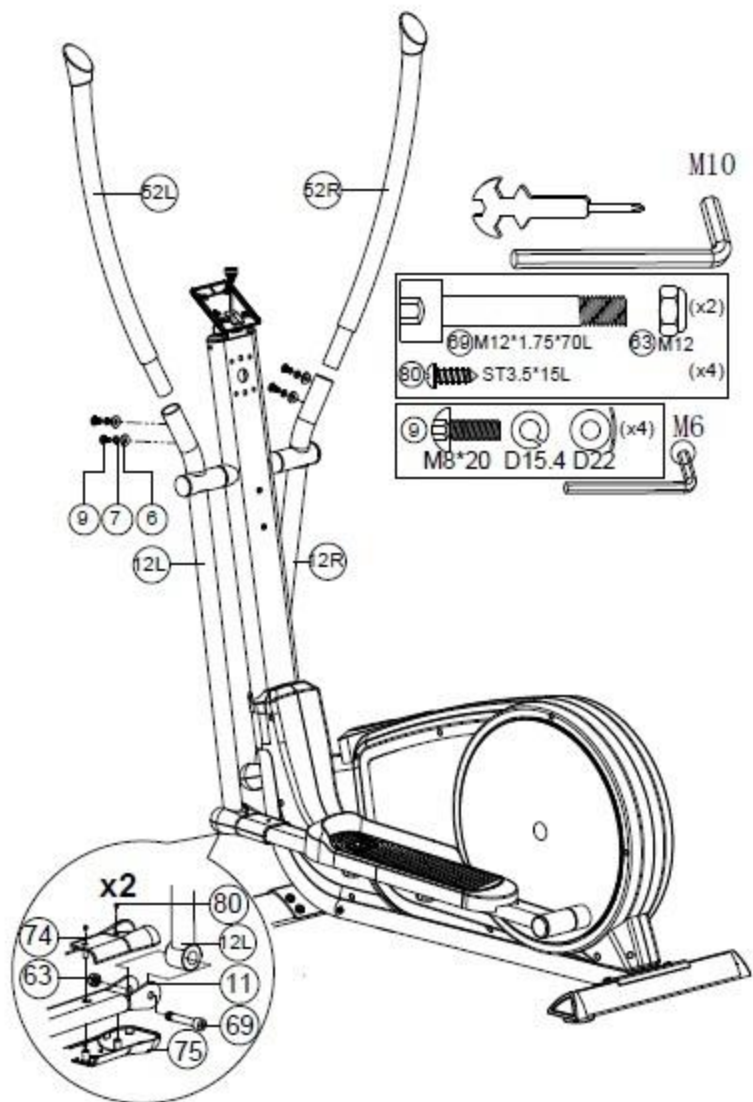

- 1) Atasati manerele mobile (52L&52R) la tuburile inferioare (12L&12R) folosind saiba curbata (6), saiba grower (7) surubul imbus (9).
- 2) Conectati tuburile mobile inferioare (12L&12R) la suportul pentru pedale (11) cu ajutorul piulitei cu autoblocare (63) si a surubului (69), apoi asamblati cele 2 capace decorative (74 & 75) cu ajutorul suruburilor (80).

## PASUL 5

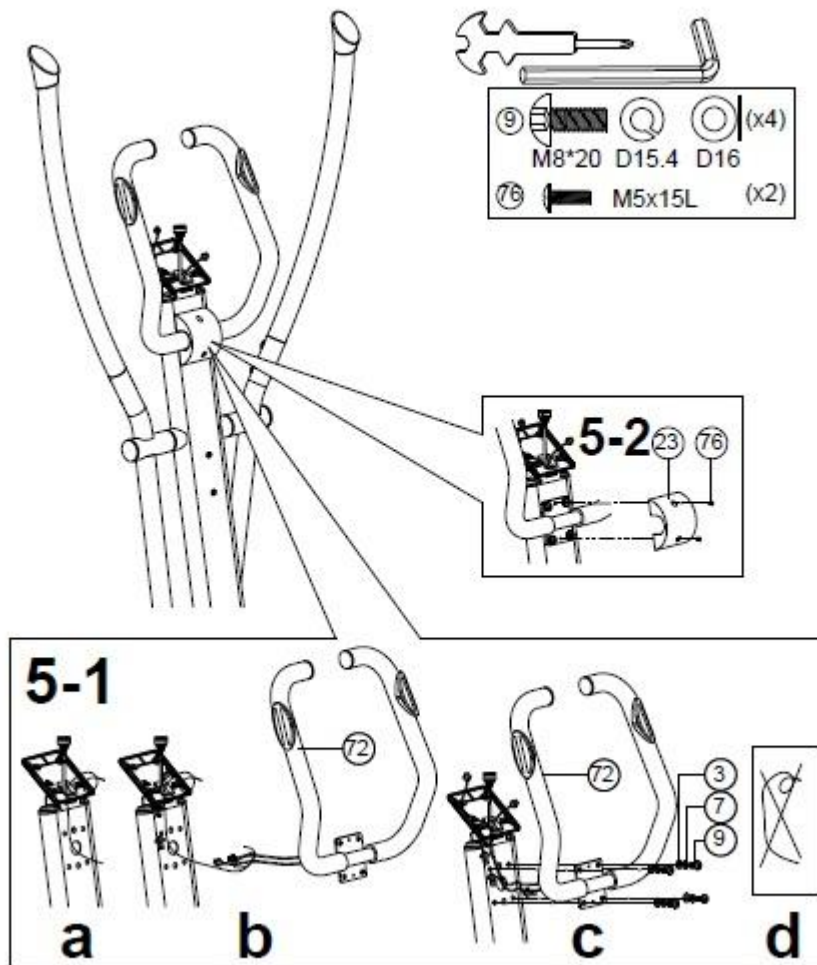

- 1) Atasati manerul fix stang si drept (72) la suportul pentru ghidon (10) folosind saiba plata (3), saiba grower (7), surubul imbus (9) conform figurii (5-1).
- 2) Atasati capacul de protectie (23) folosind surubul (76) conform figurii (5-2).

## PASUL 6

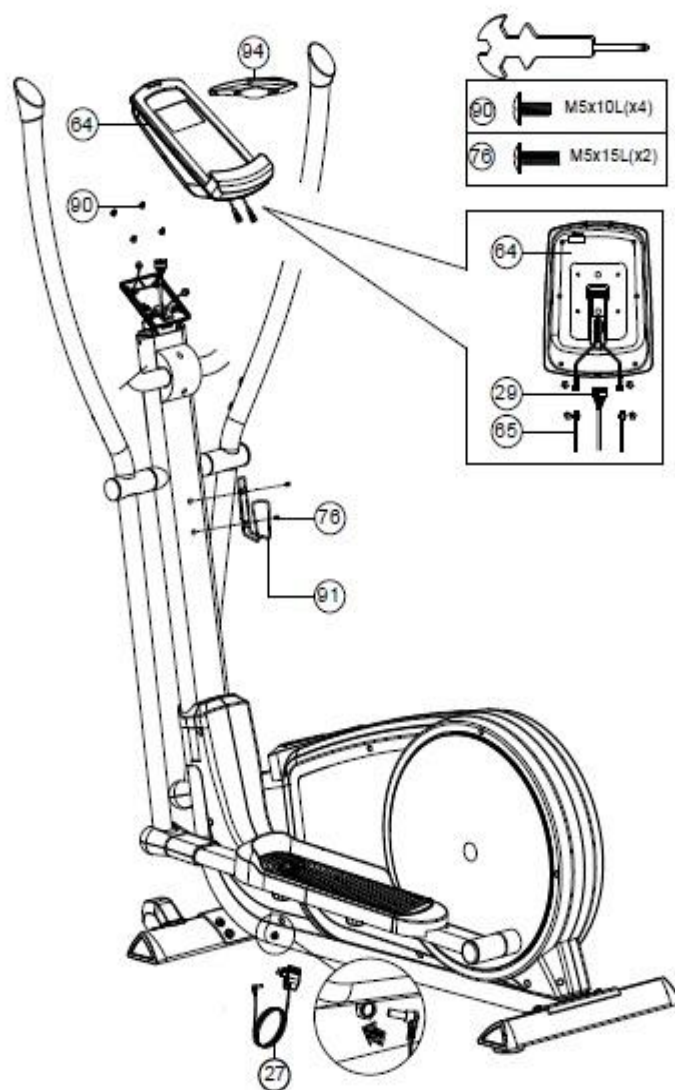

- 1) Conectati cablul calculatorului (29) si cablul senzorului pentru puls (65) la calculator (64), apoi fixati calculatorul (64) la suportul pentru ghidon (10) cu ajutorul suruburilor (90).
- 2) Conectati adaptorul (27).
- 3) Atasati suportul pentru sticla de apa (91) la suportul ghidonului cu ajutorul suruburilor (76).

## Consola SM2570+MANUAL DE INSTRUCȚIUNI



### Dispozitive compatibile

Dispozitive iOS:	Dispozitive Android:
iPod touch (a 5-a generatie) iPod touch (a 4-a generatie) iPod touch (a 3-a generatie) iPhone 5S iPhone 5C iPhone 5 iPhone 4S iPhone 4 iPhone 3GS iPad Air iPad 4 iPad 3 iPad 2 iPad iPad Min Support iOS 5.0 sau mai noi	Tableta Android OS 4.0 Rezolutie tableta 1280X800 pixeli Telefon Android OS 2.2 Rezolutii telefon Android: 1920X1080 pixeli 1280X800 pixeli 1280X760 pixeli 800X480 pixeli

### FUNCTII ECRAN

FUNCTIE	DESCRIERE
TIME	Afiseaza durata exercitiului. Valori cuprinse intre: 0:00 ~ 99:59
SPEED	Afiseaza viteza cu care se efectueaza exercitiul. Valori cuprinse intre: 0.0 ~ 99.9
DISTANCE	Afiseaza distanta parcursa.



	Valori cuprinse intre: 0.0 ~ 99.9
CALORIES	Afiseaza caloriile consumate in timpul antrenamentului. Valori cuprinse intre: 0 ~ 999
PULSE	Afiseaza pulsul.
RPM	Afiseaza numarul de rotatii pe minut. Valori cuprinse intre: 0 ~ 999
WATT	Afiseaza consumul de energie.
MANUAL	Modul Manual
PROGRAM	Cuprinde 3 programe: Beginner, Advance, Sporty
CARDIO	Program Cardio ce vizeaza ritmul cardiac.

## TASTE

TASTA	DESCRIERE
Up	<ul style="list-style-type: none"> <li>• Creste nivelul rezistentei</li> <li>• Alegere selectie.</li> </ul>
Down	<ul style="list-style-type: none"> <li>• Scade nivelul rezistentei</li> <li>• Alegere selectie.</li> </ul>
Mode	<ul style="list-style-type: none"> <li>• Confirma setarea sau selectia.</li> </ul>
Reset	<ul style="list-style-type: none"> <li>• Tineti apasata tasta RESET timp de 2 secunde pentru a reseta datele</li> <li>• Revenire la meniul principal.</li> </ul>
Start/ Stop	<ul style="list-style-type: none"> <li>• Incepeti sau finalizati programul de exercitii.</li> </ul>
Recovery	<ul style="list-style-type: none"> <li>• Afiseaza starea de revenire la normal a rotmului cardiac.</li> </ul>
Body fat	<ul style="list-style-type: none"> <li>• Afiseaza procentul grasimii din corp.</li> </ul>

## PORNIRE

Conectat la sursa de alimentare, calculatorul va porni si va afisa toate functiile pe ecran timp de 2 secunde. Dupa 4 minute in care nu pedalati consola va intra in modul pentru economisire a energiei.

Daca apasati orice tasta, consola va reporni.

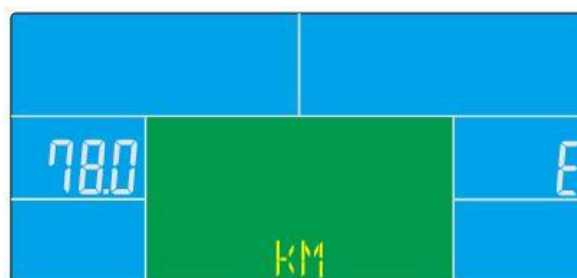
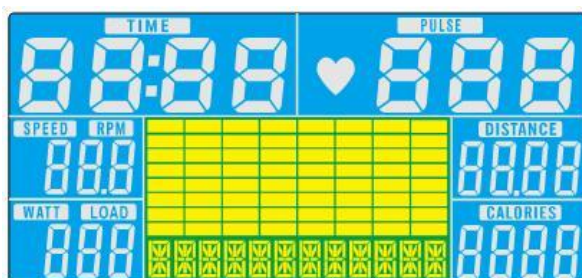

## SELECTARE PROGRAM

Apasati UP si Down pentru a selecta programul dorit: Manual  Beginner  Advance  Sporty  Cardio  
 Watt

## MANUAL MODE

Apasati START din meniul principal pentru a incepe programul de exercitii in modul manual.

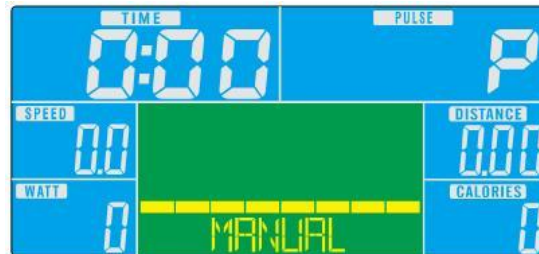

- 1) Apasati UP sau DOWN pentru a selecta programul dorit, alegeti Manual si apasati Mode pentru accesare.
- 2) Apasati UP sau DOWN pentru a preseta TIMPUL, DISTANTA, CALORIILE, PULSUL si apasati MODE pentru confirmare.
- 3) Apasati START/STOP pentru a incepe programul de exercitii. Apasati UP sau DOWN pentru ajustarea nivelului de dificultate.
- 4) Apasati START/STOP daca doriti sa luati o pauza. Apasati RESET pentru a va intoarce la meniul principal.

## BEGINNER MODE- PROGRAMUL PENTRU INCEPATORI



- 1) Apasati UP sau DOWN pentru a selecta programul dorit, alegeti Beginner mode si apasati Mode pentru accesare.
- 2) Apasati UP sau DOWN pentru a preseta timpul- TIME
- 3) Apasati START/STOP pentru a incepe exercitiul. Apasati UP sau DOWN pentru ajustarea nivelului de dificultate.
- 4) Apasati START/STOP daca doriti sa luati o pauza. Apasati RESET pentru a va intoarce la meniul principal.

## ADVANCE MODE- PROGRAMUL PENTRU AVANSATI



- 1) Apasati UP sau DOWN pentru a selecta programul dorit, alegeti Advance mode si apasati Mode.
- 2) Apasati UP sau DOWN pentru a seta timpul-TIME.
- 3) Apasati START/STOP pentru a incepe exercitiul. Apasati UP sau DOWN pentru reglarea dificultatii.
- 4) Apasati START/STOP pentru a pauza exercitiul. Apasati RESET pentru a va intoarce la meniul principal.

## SPORTY MODE



- 1) Apasati UP sau DOWN pentru a selecta programul, alegeti Sporty mode si apasati Mode pentru accesare.
- 2) Apasati UP sau DOWN pentru a seta timpul-TIME
- 3) Apasati START/STOP pentru a incepe exercitiul. Apasati UP sau DOWN pentru ajustarea nivelului de dificultate.
- 4) Apasati START/STOP pentru a pauza exercitiul. Apasati RESET pentru a va intoarce la meniul principal.

## CARDIO MODE



- 1) Apasati UP sau DOWN pentru a selecta programul, alegeti H.R.C. si apasati Mode pentru a accesa.
- 2) Apasati UP sau Down pentru a selecta 55%.75%.90% sau TAG (TARGET H.R.) (implicit: 100).
- 3) Apasati UP sau DOWN pentru a seta timpul-TIME.
- 4) Apasati START/STOP pentru a incepe sau a finaliza exercitiul. Apasati RESET pentru a va intoarce la meniul principal.

## WATT MODE

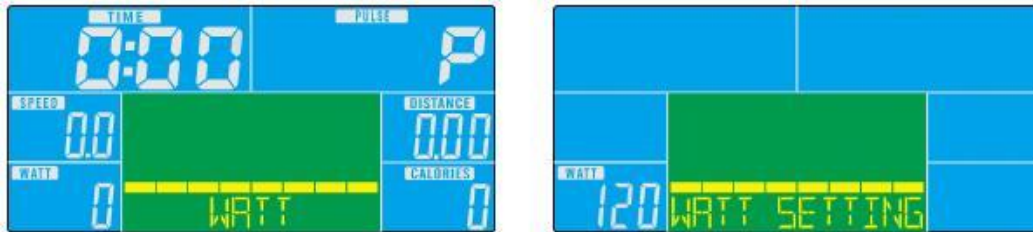

- 1) Apasati UP sau DOWN pentru a selecta programul, alegeti WATT si apasati Mode pentru a accesare.
- 2) Apasati UP sau DOWN pentru a seta WATT target. (implicit: 120)
- 3) Apasati UP sau DOWN pentru a seta timpul-TIME.
- 4) Apasati START/STOP pentru a incepe exercitiul. Apasati UP sau DOWN pentru ajustarea nivelului Watt
- 1) Apasati START/STOP pentru a pauza exercitiul. Apasati RESET pentru a va intoarce la meniul principal.

## iConsole+ APP

Porniti Bluetooth pe tableta, cautati consola si selectati conectare. (parola: 0000). Porniti iconsola+ app pe tableta, si incepeti programul de exercitii cu tableta.



### NOTA:

1. Cand consola se conecteaza la tableta prin Bluetooth, consola se va opri.
2. Daca parasiti iConsole app si opriti Bluetooth-ul de pe iPad, atunci consola va porni din nou .

L.A.3.02.2016